

JC CARTER LLC

50 GPM LNG NOZZLE OPERATION AND SERVICE MANUAL

MODELS 50E701 -1, -2, -3

MANUAL P/N C01340

REV H





Global Leader in Cryogenic Nozzle Technology

Table of Contents

Key Labels.....4

Introduction5

JC Carter Model 50E701 Nozzle Features & Specifications6

OPERATING INSTRUCTIONS.....7

 Safety Precautions: 8

 Overview 9

 Fueling Procedure 10

MAINTENANCE/SERVICE13

 Daily Nozzle Maintenance: 14

 Each Fueling: 14

 Suggested Maintenance: 14

Seals 14

Seal Maintenance..... 15

 Poppet Seal Disc..... 16

INSTALLATION/SERVICE/REPAIRS17

 Nozzle Installation:..... 18

Nozzle With Installation Kit B91546-1 18

Nozzle With Installation Kit B91546-3 20

Installation Components 20

Spring Energized Seal Installation/Replacement 21

 Poppet Seal Disc Installation/Replacement..... 23

For Models 50E701 &-1:..... 23

Installation/Replacement..... 24

For Models 50E701-2 &-3: 28

Installation/Replacement..... 29

TROUBLESHOOTING REFERENCE GUIDE32

 No LNG 33

 Handles Will Not Engage..... 33



Global Leader in Cryogenic Nozzle Technology

Nozzle Will Not Engage with Receptacle 33

Ice Buildup 34

Handles Will Not Disengage From The Receptacle..... 34

LNG Is Leaking.....34

Flow Chart for Nozzle Leakage Problem Resolution35

 A. Energized Seal 36

 B. Poppet Seal Disc..... 37

 C. Union Connection..... 38

 D. Poppet -SPECIAL CASE OF LEAKAGE..... 39

 Cause Of Malfunction..... 39

NEED REPAIR?.....41



Global Leader in Cryogenic Nozzle Technology

MODELS 50E701 -1,-2,-3



LNG FUELING OPERATOR MUST BE FULLY TRAINED IN THE SAFE OPERATION OF THIS PRODUCT IN ACCORDANCE WITH REGULATIONS DETERMINED BY AUTHORITIES HAVING JURISDICTION AND ALL SERVICE WORK MUST BE CARRIED OUT BY TRAINED TECHNICIANS IN ACCORDANCE WITH REGULATIONS DETERMINED BY AUTHORITIES HAVING JURISDICTION.

JC CARTER LLC PROVIDES THIS DATA AS A GUIDELINE ONLY. COMPLIANCE WITH REGULATIONS AND REQUIREMENTS IS THE RESPONSIBILITY OF THOSE PERFORMING THE WORK DESCRIBED HEREIN.

WARNING

READ THE LNG NOZZLE OPERATION AND SERVICE MANUAL. FOLLOW ALL WARNING AND SAFETY INSTRUCTIONS. FAILURE TO DO SO MAY RESULT IN SERIOUS INJURY.



Global Leader in Cryogenic Nozzle Technology

Key Labels

DANGER	MEANING, IF THE DANGER IS NOT AVOIDED, IT WILL CAUSE DEATH OR SERIOUS INJURY
---------------	---

WARNING	MEANING, IF PREVENTIVE MEASURE IS NOT TAKEN, SERIOUS INJURY OR DEATH MAY OCCUR
----------------	---

CAUTION	MEANING, IF THE PRECAUTION IS NOT TAKEN, MINOR OR MODERATE INJURY MAY OCCUR
----------------	--



FULL FACE SHIELD



CRYOGENIC THERMAL GLOVES



CRYOGENIC SMOCK



SOLID SHOES THAT WITHSTAND CRYOGENIC LIQUIDS



Global Leader in Cryogenic Nozzle Technology

Introduction

Thank you for allowing JC Carter LLC to be a part of your business. JC Carter offers many different products for LNG. Come visit us on the web at <http://www.jccarternozzles.com>

For the safety of yourself and other people, read this manual before using the products.

Notice the **WARNING** labels and observe recommended safety guidelines of this manual and/or other authorities. You should understand the requirements and agree to the safety guidelines of using the product. Keep this manual as a reference guide.

This user manual explains how to install, use, and troubleshoot the LNG Nozzles. This manual contains essential information regarding safety, proper fueling, and maintenance/repair, with a troubleshooting/help guide included.



Global Leader in Cryogenic Nozzle Technology

JC Carter Model 50E701 Nozzle Features & Specifications

FEATURES

- Safe, secure positive shut off preventing unintended discharge before, during and after delivery
- Self- cleaning, diametric sealing prevents liquid leakage while fueling
- Unique ICE BREAKER feature allows removal of nozzle from the receptacle under most weather conditions.
- Durable design protects against damage in the field
- Unique design offers industry leading flow rates with minimal pressure drop
- Minimal discharge upon disconnection
- Designed to be compliant with ISO 16924 and ISO 12617
- Compliant with ASME B31.3

SPECIFICATION

- Fluid compatibility: LNG, LN2, Methane
- Nominal flow: 50 GPM at ≈15 PSI differential
- Max Working Pressure: 500 PSI (3.48 MPa)
- Burst pressure: 2000 PSI (13.79 MPa)
- Cv: 9
- Spillage on de-mating: less than 1cc
- Leakage during fueling: None
- Operating temperature: -320°F to +185°F (-195.56°C to +85°C)
- Storage temperature: -60°F to +120°F (-51.1°C to 48.89°C)
- Dimensions:
 - Length: 14 ½ " (370.84 mm)
 - Width (including operating handles): 6 ½" (167.64 mm)
 - Weight: 12 lbs. (5.44 kg)
 - Process connection (with adapter): 1" JIC 37° Flare fitting

CAUTION

FAILURE TO ADHERE TO THE SPECIFICATION MAY RESULT IN INJURY



Global Leader in Cryogenic Nozzle Technology

MANUAL P/N C01340

REV H

OPERATING INSTRUCTIONS

7

JC Carter

Cleveland, OH 44143 • Costa Mesa, CA 92627 • USA

www.jccarternozzles.com

THE INFORMATION CONTAINED IN THIS DOCUMENT IS THE SOLE PROPERTY OF JC CARTER LLC. ANY REPRODUCTION IN PART OR AS A WHOLE WITHOUT WRITTEN PERMISSION OF JC CARTER LLC IS PROHIBITED



Global Leader in Cryogenic Nozzle Technology

Safety Precautions:

- Always wear protective clothing as required by authorities having jurisdiction.



FULL FACE SHIELD



CRYOGENIC SMOCK



CRYOGENIC THERMAL GLOVES



SOLID SHOES THAT WITHSTAND CRYOGENIC LIQUIDS

- Follow all regulations as specified by authorities having jurisdiction.
- Read the Operation/Service Manual completely before operating.
- Keep area of operation clear of all persons other than operator.
- Use this nozzle only as described in this manual.
- Do not operate nozzle if it is damaged.
- Do not operate nozzle if any leakage occurs.

WARNING

THE OPERATOR MUST WEAR THE PROTECTIVE CLOTHING OUTLINED IN THE WARNINGS AND FOLLOW THE SAFETY INSTRUCTIONS OF THIS MANUAL. FAILURE TO DO SO MAY RESULT IN INJURY. NEVER POINT THE NOZZLE DIRECTLY AT YOURSELF OR OTHERS AT ANY TIME.

Overview

The quick disconnect single line nozzle is intended for use in NO-VENT (top fill) LNG fuel systems. A key feature of this nozzle is the independent shut-off valve located in the flow path within the nozzle. The operator mates the nozzle 50E701 to the receptacle by pushing it over the receptacle with handles pulled all the way back (See Stage 1). By pushing two handles forward, locking of the nozzle to the receptacle and opening of the internal valves is achieved, (See Stage 2) and fueling can be started. When fueling is complete, the operator returns the handles back to vent position (See Stage 3) and waits to complete venting of the residual LNG. Then the nozzle can be unlocked and de-mated by pulling two handles all the way back (See Stage 1).

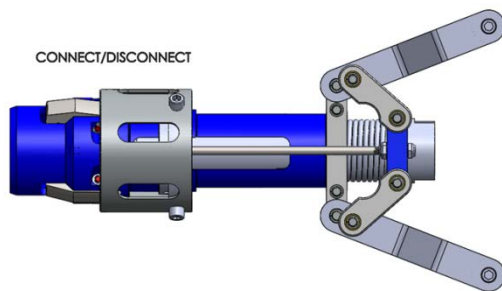

STAGE 1

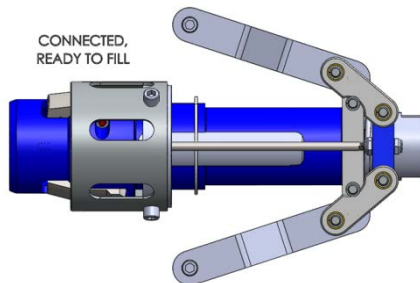

STAGE 2

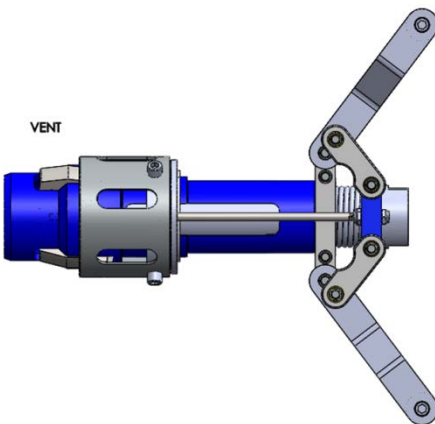

STAGE 3

IMPORTANT SAFETY STOP

Fueling Procedure



CAUTION FAILURE TO CLEAN NOZZLE AND RECEPTACLE PRIOR TO OR AFTER FUELING IS HAZARDOUS

- Connect grounding cable to vehicle.
- Remove receptacle protective cap.

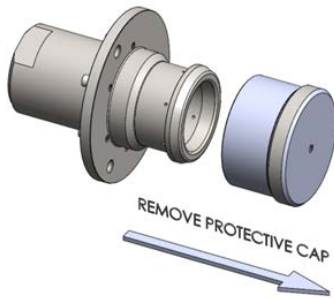

- Thoroughly clean nozzle and receptacle connections with compressed air. Ensure that no dirt or ice is visible on either the nozzle or receptacle.

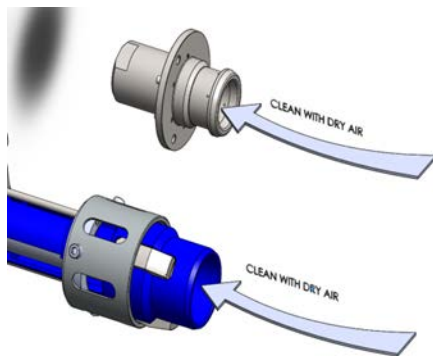

CLEAN WITH DRY AIR

- With nozzle handles completely retracted toward the operator, allowing the locking latches to open, slide the nozzle onto the receptacle until housing is squarely stopped by the receptacle flange.

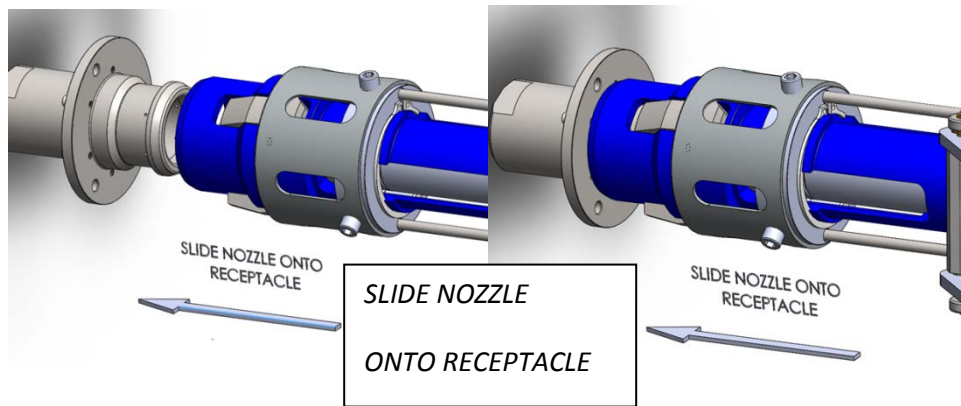

CAUTION

DO NOT FORCE NOZZLE ONTO RECEPTACLE.

- When the nozzle is located on the receptacle, push handles toward the vehicle to complete the connection and start flow.

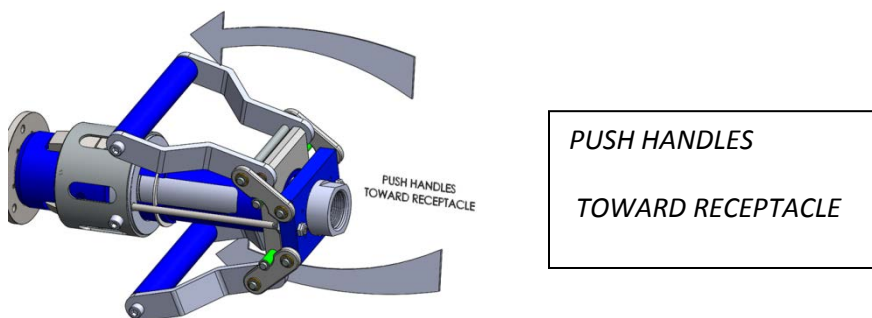

- When fueling cycle is completed, slowly pull the nozzle handles towards the operator until vent position is reached. **Do not move handles past vent position until venting from the nozzle/receptacle interface is completed.**

WARNING

IF VENTING CONTINUES, RECONNECT THE NOZZLE AND REPORT INCIDENT

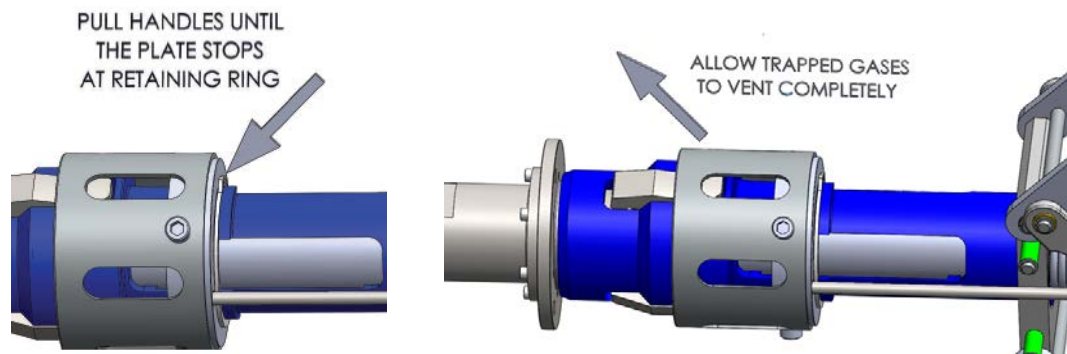

- When venting is completed, pull handles fully towards the operator to remove the nozzle from receptacle.

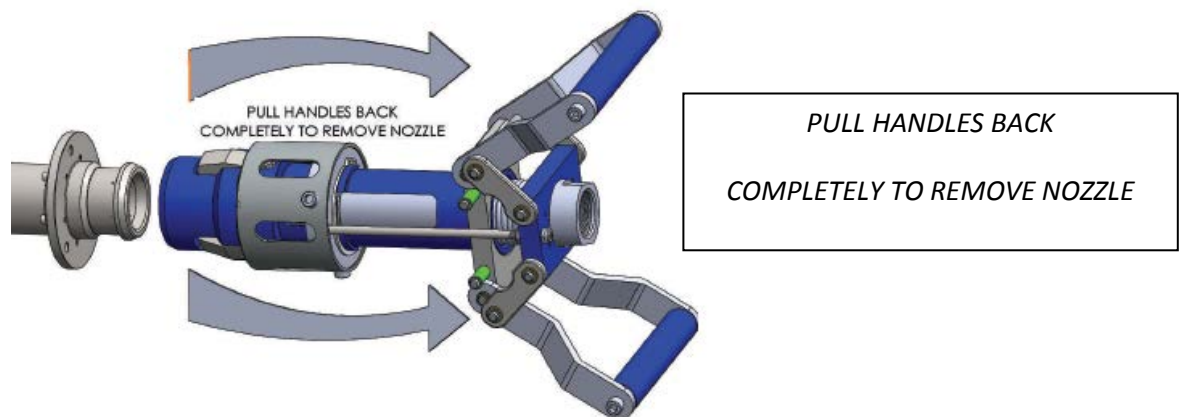

- After removal clean nozzle and receptacle surfaces with compressed air.
- Replace nozzle in the nozzle holder.
- Replace the receptacle protective cap.



Global Leader in Cryogenic Nozzle Technology

MANUAL P/N C01340

REV H

MAINTENANCE/SERVICE

13

JC Carter

Cleveland, OH 44143 • Costa Mesa, CA 92627 • USA

www.jccarternozzles.com

THE INFORMATION CONTAINED IN THIS DOCUMENT IS THE SOLE PROPERTY OF JC CARTER LLC. ANY REPRODUCTION IN PART OR AS A WHOLE WITHOUT WRITTEN PERMISSION OF JC CARTER LLC IS PROHIBITED



Global Leader in Cryogenic Nozzle Technology

Please note that JC Carter recommends the following maintenance schedule be followed to ensure trouble free operation and maximum life. Failure to follow the schedule may result in less than optimal performance or reduced operating life.

Daily Nozzle Maintenance:

At the start of each fueling day:

- Check to be sure no pressure is present in the nozzle.
- Clean out the mating end of the nozzle with dry, clean compressed air or nitrogen.

Each Fueling:

Before and after each fueling:

- Clean out the cup of the receptacle with dry, clean compressed air or nitrogen.
- Clean out the mating end of the nozzle

Suggested Maintenance:

Seals

Seals will eventually become inoperative due to wear, climate, dust, humidity and operational conditions. The environment and operating conditions will determine the safe service life of the seals. Periodic inspections and following practices described in this manual may prolong service life of the seal. It is recommended by JC Carter to change seals when leakage is noted, per instructions outlined in this manual.

Seal Maintenance

Spring Energized Seal

(P/N B78705-6)

Overview

When the seal is seated in the gland, the spring is under compression, applying force on the gland sealing surfaces creating a tight barrier to prevent gas or fluids from leaking. The spring also provides resiliency to compensate for seal wear, gland misalignment or eccentricity. While spring force provides adequate force for sealing at low pressure, at high pressure the system pressure augments the spring force to provide an even tighter seal.

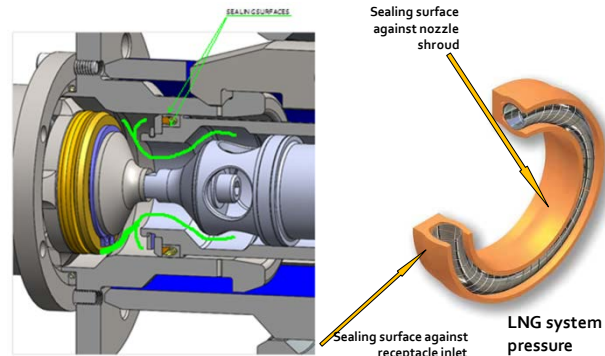

Possible Causes Of Reduction In Seal Performance

- Ice buildup in the spring coils.
- Abrasive dirt deposits on the sealing surfaces.
- Ice buildup on the sealing surfaces.
- Sharp edges on the vent holes in the receptacle can damage sealing surface.

Preventive Actions To Increase Seal Life

- Clean seal before and after every use with dry compressed air or nitrogen.
- Do not insert nozzle into receptacle if ice accumulation is present on internal receptacle surfaces or on the nozzle outlet area. Defrost ice with dry compressed air or nitrogen. If heated dry compressed air is accessible, it will reduce the defrosting time.
- Check inlet of the receptacle before engaging the nozzle. If dirt is noted, wipe it clean with a soft, lint free cloth.

Seal Replacement

(P/N B78705-6)

JC Carter recommends the spring energized seal should be replaced when leakage is noted. Due to different climate, dust, humidity, and operational conditions, the life of the spring energized seal will vary.



Global Leader in Cryogenic Nozzle Technology

Poppet Seal Disc

(P/N 212536)

Overview

The shroud sealing the surface is finished to provide a tight leak free seal when edge of the disc seal is compressed by means of the spring and the system pressure. While spring force provides adequate force for sealing at low pressure, at high pressure the system pressure augments the spring force to provide an even tighter seal.

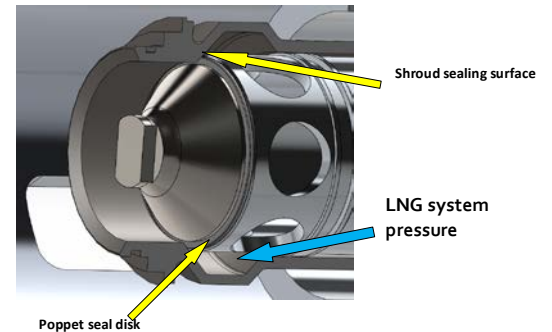

Possible Causes Of Reduction In Seal Performance

- Contaminants in the LNG system not removed during installation.
- Water condensation inside of the system which forms into ice crystals and when flow is passing over the seal, scratches and abrades the sealing edge.
- Solid contaminants brought from LNG supply bulk delivery.
- Quality of LNG

Preventive Actions To Increase Seal Life

- Do not leave connecting lines and nozzle open to atmosphere when removed from dispenser.
- Periodic maintenance of the nozzle.
- Ensure good quality of LNG supply.

Seal Replacement

JC Carter recommends the poppet seal disc should be replaced when leakage is noted. Due to different climate, dust, humidity, and operational conditions, the life of the poppet seal disc will vary. For disassembly and reassembly of the seal disc for 50E701 &-1, see page 23 and 50E701-2 &3 see page 28.



Global Leader in Cryogenic Nozzle Technology

MANUAL P/N C01340

REV H

INSTALLATION/SERVICE/REPAIRS

17

JC Carter

Cleveland, OH 44143 • Costa Mesa, CA 92627 • USA

www.jccarternozzles.com

THE INFORMATION CONTAINED IN THIS DOCUMENT IS THE SOLE PROPERTY OF JC CARTER LLC. ANY REPRODUCTION IN PART OR AS A WHOLE WITHOUT WRITTEN PERMISSION OF JC CARTER LLC IS PROHIBITED



Global Leader in Cryogenic Nozzle Technology

Nozzle Installation:

CAUTION

OPEN NOZZLE PACKAGE ONLY IN A DRY, PROTECTED AREA. DO NOT ALLOW WATER OR OTHER CONTAMINANTS TO ENTER THE INTERNAL MECHANISM OF THE COUPLING.

Nozzle With Installation Kit B91546-1

Installation Components:

- Stainless Steel Adapter Union P/N C01578-016
- Boss Seal P/N B91668-016-T-001
- PTFE O-Ring (Alternate to Boss Seal) P/N 93238-916
- Anti-seize compound Swagelok Silver Goop P/N 93222
- Two wrenches are required to tighten the union: a 1-5/8" and 1-3/4" wrench to hold the nozzle.

Installation Of Nozzle/Hose Union

Do not use pipe sealant or Teflon tape.

- Install union to nozzle before connecting to the hose.
- Place nozzle on flat surface with connection end facing upward.
- Apply anti-seize compound on the inner threads of the nozzle. Be sure there is no anti-seize compound on the sealing surface.

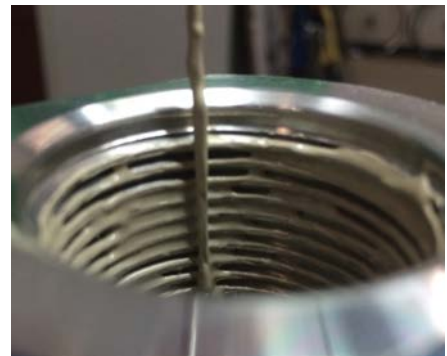
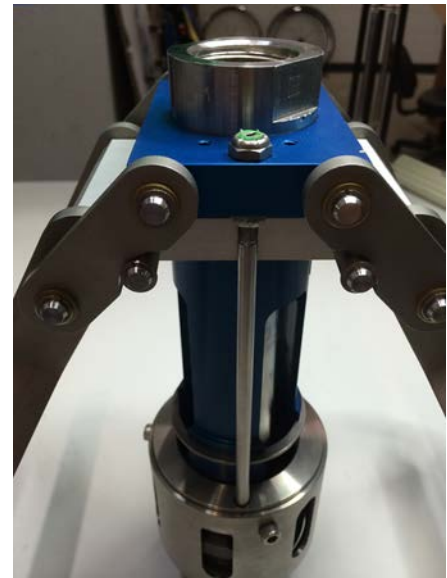

- Place Boss Seal inside threaded port with widest part of the seal at the top

NOTE: Seal must be handled with care to avoid damaging the seal coating.

- Use appropriate wrenches to tighten the adaptor.
- Tighten the adaptor to the nozzle between 100 and 120 ft-lb.

NOTE: Do not over tighten.

IF OVER TIGHTENING HAPPENS BETWEEN THE ADAPTOR AND NOZZLE POSSIBLE GALLING CAN OCCUR, WHICH MAY REQUIRE SHROUD REPLACEMENT. JC CARTER IS NOT LIABLE FOR DAMAGE THAT MAY OCCUR AS A RESULT OF FAILURE TO FOLLOW INSTRUCTIONS INTENDED FOR THIS ASSEMBLY. JC CARTER LLC IS NOT RESPONSIBLE FOR DUE NEGLIGENCE OF THIS ACTION OR ANY OTHER ACTION RESULTING AND/OR PERTAINING TO ASSEMBLY.

PRODUCT(S) WARRANTY MAY BE NULL AND VOID. SEE WARRANTY FOR MORE DETAIL.

- Pressure test connection with nitrogen at 250 PSI, after nozzle is connected to the hose.
- Do not put nozzle into service if any connections are found to be leaking.

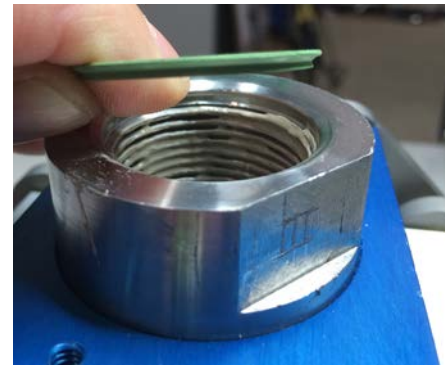



Global Leader in Cryogenic Nozzle Technology

Nozzle With Installation Kit B91546-3

MANUAL P/N C01340

REV H

Installation Components:

- Brass Adapter Union P/N 93242-016
- Boss Seal P/N B91668-016-T-001
- PTFE O-Ring (Alternate to Boss Seal) P/N 93238-916
- Two wrenches are required to tighten the union, a 1-5/8" and 1-3/4" wrench to hold the nozzle.

Installation Of Nozzle/Hose Union

Do not use pipe sealant or Teflon tape.

- Install union to nozzle before connecting to the hose.
- Place nozzle on flat surface with connection end facing upward.

- Use appropriate wrenches to tighten the adaptor.
- Tighten the adaptor to the nozzle between 100 and 120 ft-lb.

NOTE: Do not over tighten.

- Pressure test connection with nitrogen at 250 PSI, after nozzle is connected to the hose.
- Do not put nozzle into service if any connections are found to be leaking.

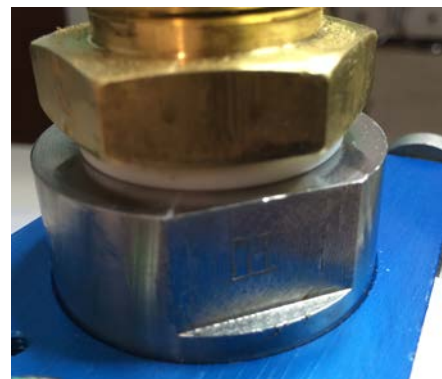



Global Leader in Cryogenic Nozzle Technology

Spring Energized Seal Installation/Replacement

Installation Components:

- Kit, Seal Replacement (P/N B91548-1) content:
 - Seal, Spring Energized P/N B78705-6
 - Retainer Seal P/N B84398-1
 - Ring Retainer P/N 93223-112
- Tools required:
 - Retaining Ring Pliers



Installation/Replacement

- Push the nozzle handles all the way up and put nozzle on a flat surface with nose piece facing up.
- Remove Retaining ring (B91877SS-112) using Retaining Ring Pliers

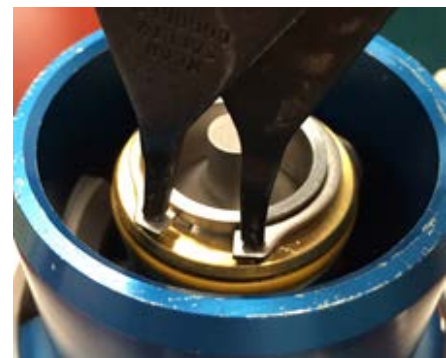
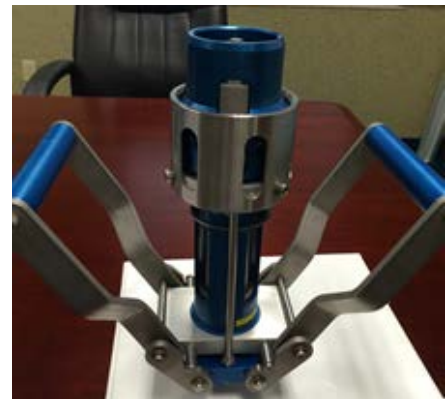

- Remove Brass Seal Retainer (B84398-1)

- Remove used Spring Energized Seal (B78705-6)



- Carefully install new Spring Energized Seal (B78705-6)

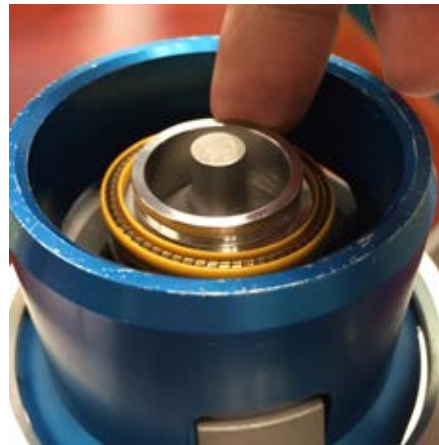

Note: Pay attention to direction of seal opening; it must be face up (see picture).

- Reverse order to reassemble.

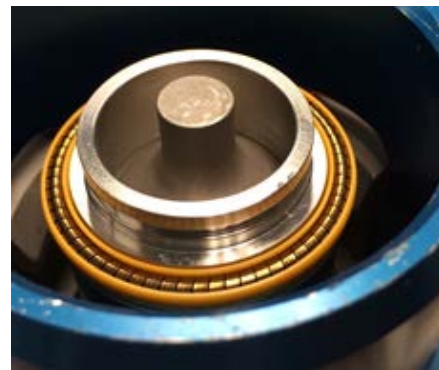



Global Leader in Cryogenic Nozzle Technology

Poppet Seal Disc Installation/Replacement

When disassembling and reassembling the seal disc, the following components are required:

For Models 50E701 &-1:

- Nosepiece P/N 212535
- Seal Disc P/N 212536
- Body P/N 212537
- Sleeve, Poppet P/N B91415-1
- Socket Head Cap Screw P/N NAS1351C3-8
- Flat Washer P/N AN960-C10L
- Anti-seize Compound Swagelok Silver Goop P/N 93222



Another viable option if seal disc needs to be replaced is a new poppet assembly (P/N 212538) with sleeve, poppet (P/N B91415-1).

Tools Required:

- Adjustable Torque Screwdriver
- 1/4" Square drive, 5/32" hex size, 4-7/16" long
- Retaining Ring Pliers



Note: Use of functionally equivalent tools is permissible.



Global Leader in Cryogenic Nozzle Technology

Installation/Replacement

- Remove Union (See Nozzle/Hose installation Pg. 18)
- Locate Internal Retaining Ring (P/N B78698-125)

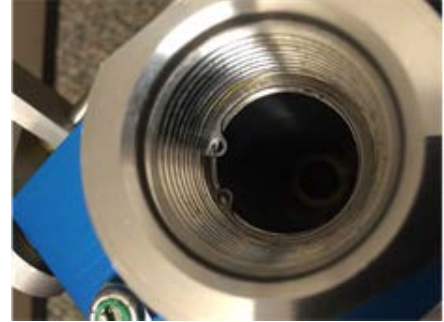

- With Retaining Ring Pliers carefully remove retaining ring.

NOTE: EXERCISE CAUTION INTERNAL PARTS ARE SPRING LOADED.



- Remove Tube Spacer (P/N B84399-1)



- Remove Spring Seat (P/N B84383-1)



- Remove Compression Spring (P/N B84373-1)



- Turn nozzle upside down. With your finger, push the poppet assembly down.



- Poppet Assembly (P/N 212538) is removed.



- If Phillips screw is installed as shown, use Phillips screwdriver to remove it. Otherwise, use 5/32" hex Allen wrench.





Global Leader in Cryogenic Nozzle Technology

- Put the Flat Washer (P/N AN960-C10L) on the screw (P/N NAS1351C3-8), insert it into the Poppet Body (P/N 212537) hole and install the Seal Disc (P/N 212536).



- Apply Anti-seize compound as shown

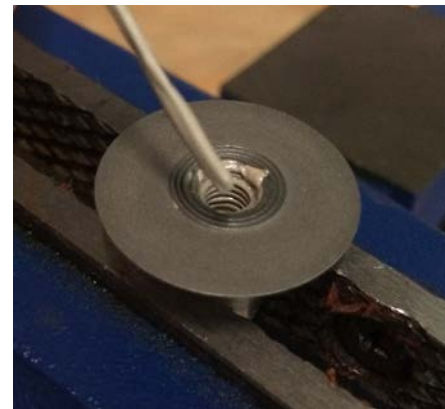

- Set the Torque Screwdriver to 42 in-lb per manufacturer instructions.





Global Leader in Cryogenic Nozzle Technology

- Hold the Poppet Assembly in a bench vise and torque the screw to 42 in-lb.



- Clean off excess Anti-Seize Compound from the Poppet Assembly and reinstall back into the nozzle.



Global Leader in Cryogenic Nozzle Technology

For Models 50E701-2 &-3:

- Nosepiece P/N 212535
- Seal Disc P/N 212536
- Body P/N 93239
- Socket Head Cap Screw P/N NAS1351C3-10
- Flat Washer P/N AN960-C10L
- Anti-seize Compound Swagelok Silver Goop P/N 93222



Another viable option if seal disc needs to be replaced is a new poppet assembly (P/N 93243).



Tools Required:

- Adjustable Torque Screwdriver
- 1/4" Square drive, 5/32" hex size, 4-7/16" long
- Retaining Ring Pliers



Note: Use of functionally equivalent tools is permissible.



Global Leader in Cryogenic Nozzle Technology

Installation/Replacement

- Remove Union (See Nozzle/Hose installation Pg. 18)
- Locate retaining ring (P/N B78698-125)

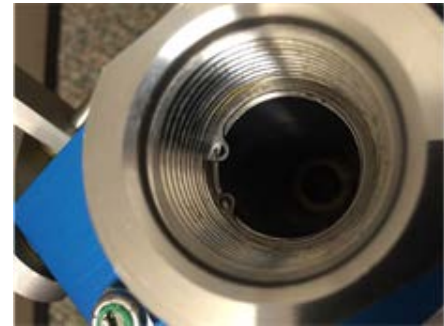

- With Retaining Ring Pliers carefully remove Internal Retaining Ring.

NOTE: EXERCISE CAUTION INTERNAL PARTS ARE SPRING LOADED.



- Remove Tube Spacer (P/N B84399-1)



- Remove Spring Seat (P/N B84383-1)



- Remove Compression Spring (P/N B84373-1)



- Turn nozzle upside down. With your finger push the poppet assembly down.



- Poppet Assembly (P/N 93243) is removed.



- Hold nosepiece in bench vise and use 5/32" hex Allen wrench to remove screw.



- Put the Flat Washer (P/N AN960-C10L) on the Screw (P/N NAS1351C3-10), insert it into the Poppet Body (P/N 93239) hole and install the Seal Disc (P/N 212536).



- Apply Anti-seize compound as shown

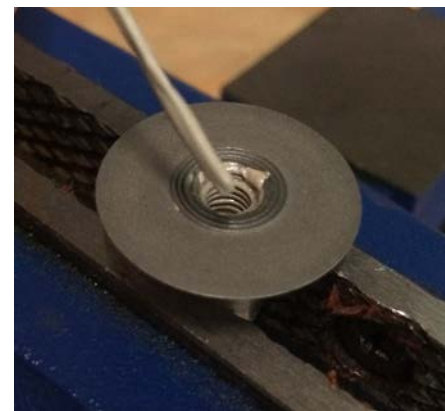

- Set the Torque Screwdriver to 42 in-lb per manufacturer instructions.



- Install the Poppet Assembly in the bench vise and torque the screw to 42 in-lb.



- Clean off excess Anti-Seize Compound from the Poppet Assembly and reinstall in the nozzle.



Global Leader in Cryogenic Nozzle Technology

MANUAL P/N C01340

REV H

TROUBLESHOOTING REFERENCE GUIDE

32

JC Carter

Cleveland, OH 44143 • Costa Mesa, CA 92627 • USA

www.jccarternozzles.com

THE INFORMATION CONTAINED IN THIS DOCUMENT IS THE SOLE PROPERTY OF JC CARTER LLC. ANY REPRODUCTION IN PART OR AS A WHOLE WITHOUT WRITTEN PERMISSION OF JC CARTER LLC IS PROHIBITED



Global Leader in Cryogenic Nozzle Technology

CAUTION Follow all safety requirements when operating the nozzle.

LNG supply needs to be properly filtered and instructions for proper storage of the nozzle must be followed. Do not leave nozzle on the ground. Following these steps will help ensure water will not collect inside the nozzle and then refreeze forming ice crystals and causing the poppet to lock-up.

SYMPTOM:

No LNG

- Make sure supply of LNG is turned on.
- Make sure nozzle is connected to receptacle and engaged.
- Check with station or facility.

Handles Will Not Engage

- Make sure nozzle is seated on receptacle.
- Make sure no objects are in between nozzle and receptacle when engaging.
- Unit may have been damaged. DO NOT USE. Contact station/distributor/facility.

Nozzle Will Not Engage with Receptacle

- Make sure nozzle is seated on receptacle
- Make sure no objects are in between nozzle and receptacle when engaging
- Unit may have been damaged. DO NOT USE. Contact station/distributor/facility.

CAUTION DO NOT FORCE NOZZLE ONTO RECEPTACLE.



Global Leader in Cryogenic Nozzle Technology

Ice Buildup

- This can happen when refueling; the unique design of the JC Carter nozzle accounts for this.
- May need to engage and disengage the nozzle handles a few times if ice buildup is heavy.
- Remove ice buildup with dry air.

Handles Will Not Disengage From The Receptacle

DANGER STOP! TURN OFF THE SUPPLY TO THE LNG

- See ice buildup
- Unit might have been damaged. DO NOT USE. Contact station/distributor/facility.

LNG Is Leaking

DANGER STOP! TURN OFF THE SUPPLY TO THE LNG

Energized Seal (Pg. 36)

Poppet Seal Disc (Pg. 37)

Union Connection (Pg. 38)

Poppet (Pg. 39)



Global Leader in Cryogenic Nozzle Technology

Flow Chart for Nozzle Leakage Problem Resolution

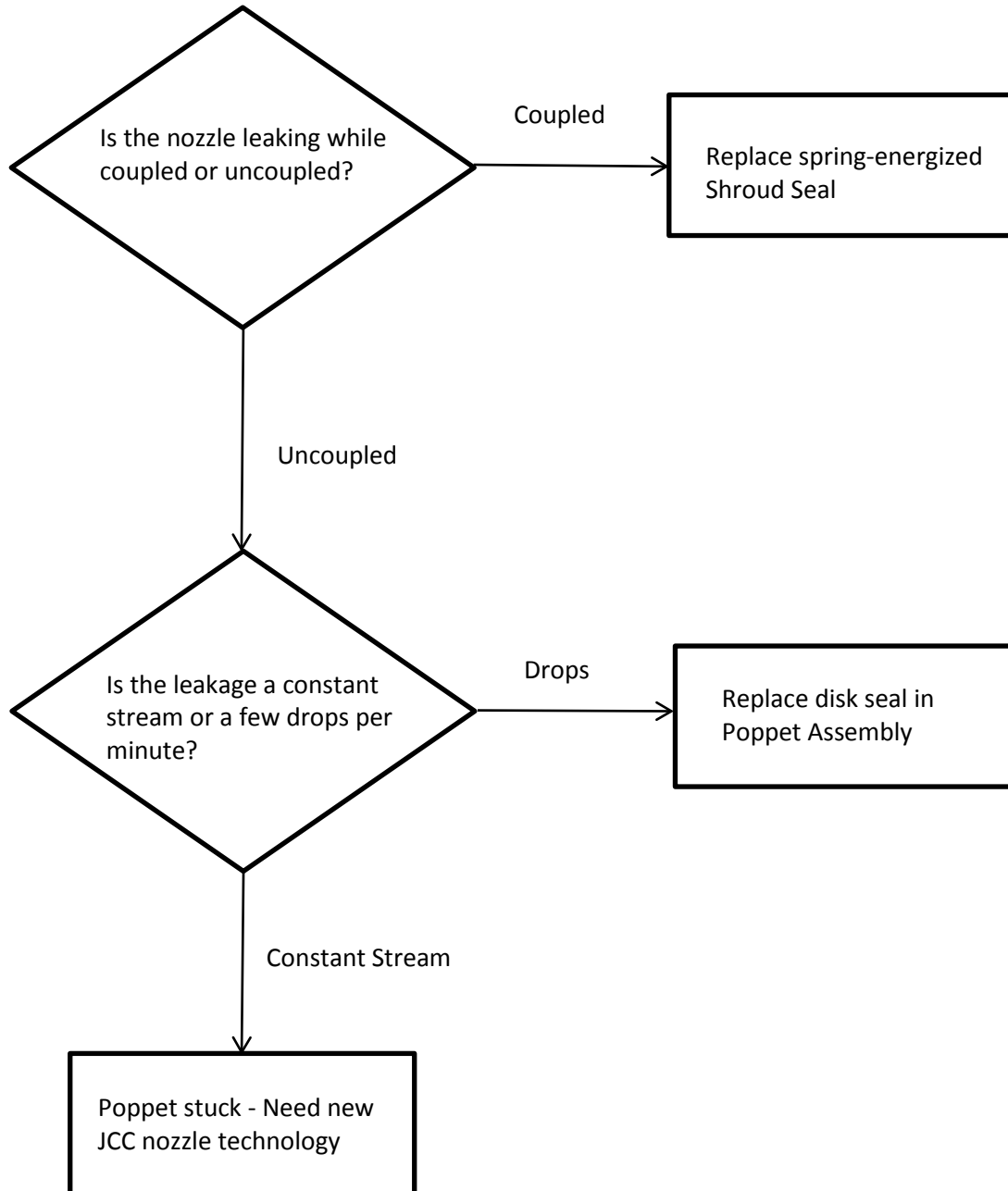

A. Energized Seal

WHEN THE SPRING ENERGIZED SEAL IS WORN OR DAMAGED THE LEAKAGE CAN BE DETECTED ONLY WHEN NOZZLE IS COUPLED TO THE RECEPTACLE AND PRESSURIZED.

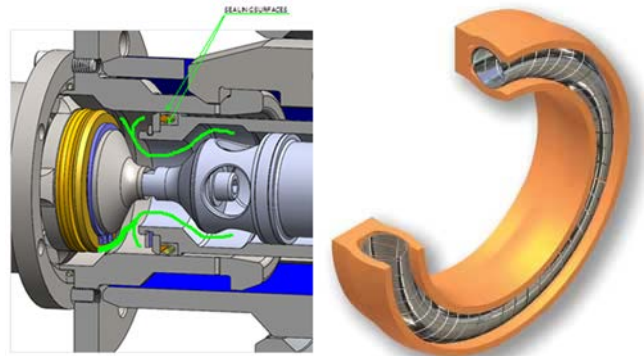

Signs Of Leakage:

- Forceful streams of gas are escaping around the end of the nozzle near the receptacle
- LNG is dripping around front part of the nozzle

Possible Causes Of Reduction In Seal Performance

- Ice buildup in the spring coils.
- Abrasive dirt deposits on the sealing surfaces.
- Ice buildup on the sealing surfaces.
- Sharp edges on the receptacle vent holes can damage sealing surface.

Preventive Actions To Increase Seal Life

- Clean seal before and after every use with dry compressed air or nitrogen.
- Do not insert nozzle into receptacle if ice accumulation is noted on internal receptacle surface or on the nozzle outlet area. Defrost ice with dry compressed air or nitrogen. If heated dry compressed air is available it will reduce the defrosting time.
- Check inlet of the receptacle before engaging the nozzle. If dirt is noted, wipe it clean with a soft, lint-free cloth.

B. Poppet Seal Disc

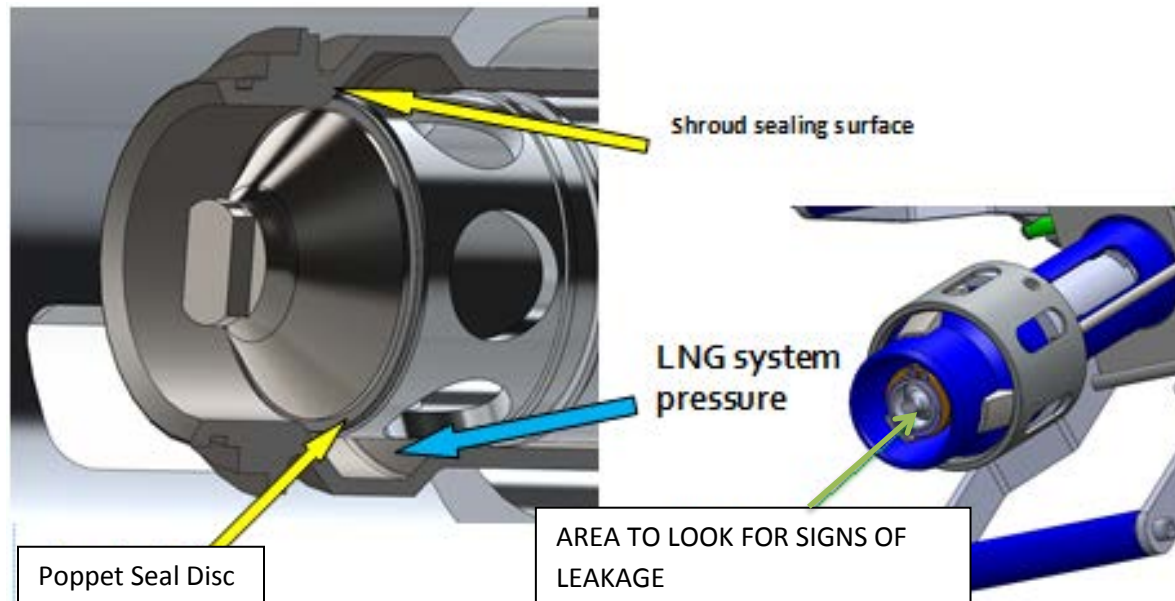

WHEN THE POPPET SEAL DISC IS WORN OR DAMAGED THE LEAKAGE CAN BE DETECTED ONLY WHEN NOZZLE IS DECOUPLED FROM THE RECEPTACLE AND PRESSURIZED.

Signs Of Leakage:

- Forceful streams of gas are escaping around the poppet nosepiece.
- Small amount of liquid gas spraying out of the nozzle outlet.

Possible Causes Of Reduction In Seal Performance

- Contaminants in the LNG system not removed during installation.
- Water condensation inside of the LNG system which forms into ice crystals and when flow passes over the seal, thereby scratching and abrading the sealing edge.
- Solid contaminants within the LNG bulk delivery supply.
- Quality of LNG.

Preventive Actions To Increase Seal Life

- Do not leave connecting lines and nozzle orifices open to atmosphere when removed.
- Periodic maintenance and cleaning of the nozzle.
- Insure good quality of LNG supply.

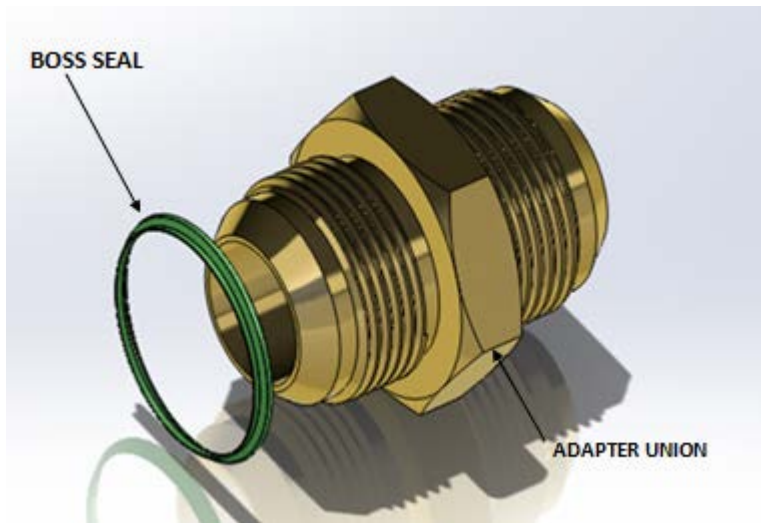

Signs Of Leakage:

- Forceful streams of gas are escaping around the union connection.
- Small amount of liquid gas is spraying out of the nozzle connection and/or hose connection.

Possible Causes Of The Union Connection Failure

- Wrong connection size for union and hose.
- Abrasive dirt deposits on the sealing surfaces.
- Ice buildup on the sealing surfaces.
- Seals are damaged
- Connection of union to nozzle may be loose or seated incorrectly.
- Connection of hose to union may be loose or seated incorrectly.

Preventive Actions

- Do not use pipe sealant or Teflon tape.
- Periodic maintenance and inspection of the union.
- Insure good quality of LNG supply.

D. Poppet -SPECIAL CASE OF LEAKAGE



Sometimes leakage can occur due to the poppet not closing off LNG supply. Visual appearance of the escaping LNG could range from a mist to full exposure of gases; this depends on the rate of pressure and the position of the poppet.

NOTE: THIS TYPE OF LEAK IS NOT DUE TO FAULTY SEALS. SEAL REPLACEMENT WILL NOT RECTIFY THE PROBLEM AND IS NOT REQUIRED.

Cause Of Malfunction

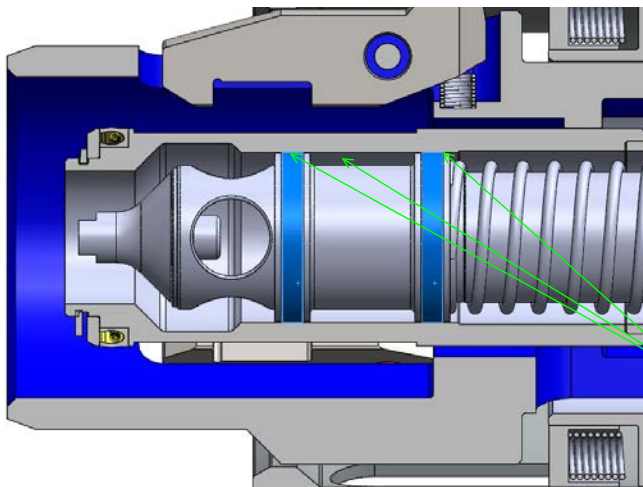

Over time, ice and other contaminants from the LNG system can accumulate in these areas. As the result of connection and refueling, water can condense around the poppet, and the poppet then freezes in place when fueling LNG.

AREAS OF ICE AND CONTAMINANT ACCUMULATION

WATER

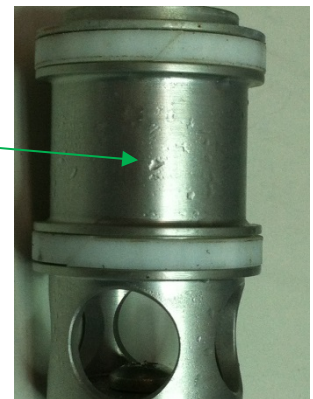
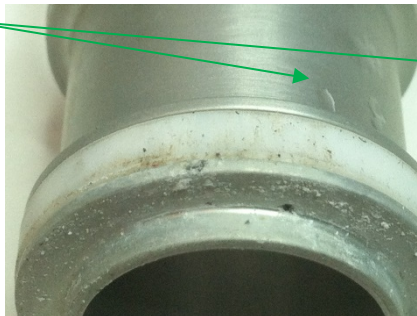



Global Leader in Cryogenic Nozzle Technology

Preventive Actions

- LNG system should be free of any contaminants, debris or water.
- During maintenance, keep cold equipment isolated from ambient air.
- When this type of event happens, remove the nozzle from the dispenser and clean and dry the internals of the nozzle.



Global Leader in Cryogenic Nozzle Technology

MANUAL P/N C01340

REV H

NEED REPAIR?

Contact your local authorized repair service center for:

- Service & Maintenance
- Warranty service
- Purchasing products, parts and accessories
- Product information

To find an Authorized JC Carter Parts and Repair Service Center, please visit us at:

WWW.JCCARTERNOZZLES.COM

41

JC Carter

Cleveland, OH 44143 • Costa Mesa, CA 92627 • USA

www.jccarternozzles.com

THE INFORMATION CONTAINED IN THIS DOCUMENT IS THE SOLE PROPERTY OF JC CARTER LLC. ANY REPRODUCTION IN PART OR AS A WHOLE WITHOUT WRITTEN PERMISSION OF JC CARTER LLC IS PROHIBITED